

De'Longhi De'Longhi SpA
TREVISO-ITALIA
Made in Italy
CAT:MA TYP:EAM3 __.S EX:--
220-240V - 50/60Hz
SER. NR.:
S02

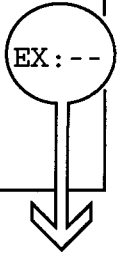

CONTROLLARE L'ETICHETTA
CHECK THE LABEL

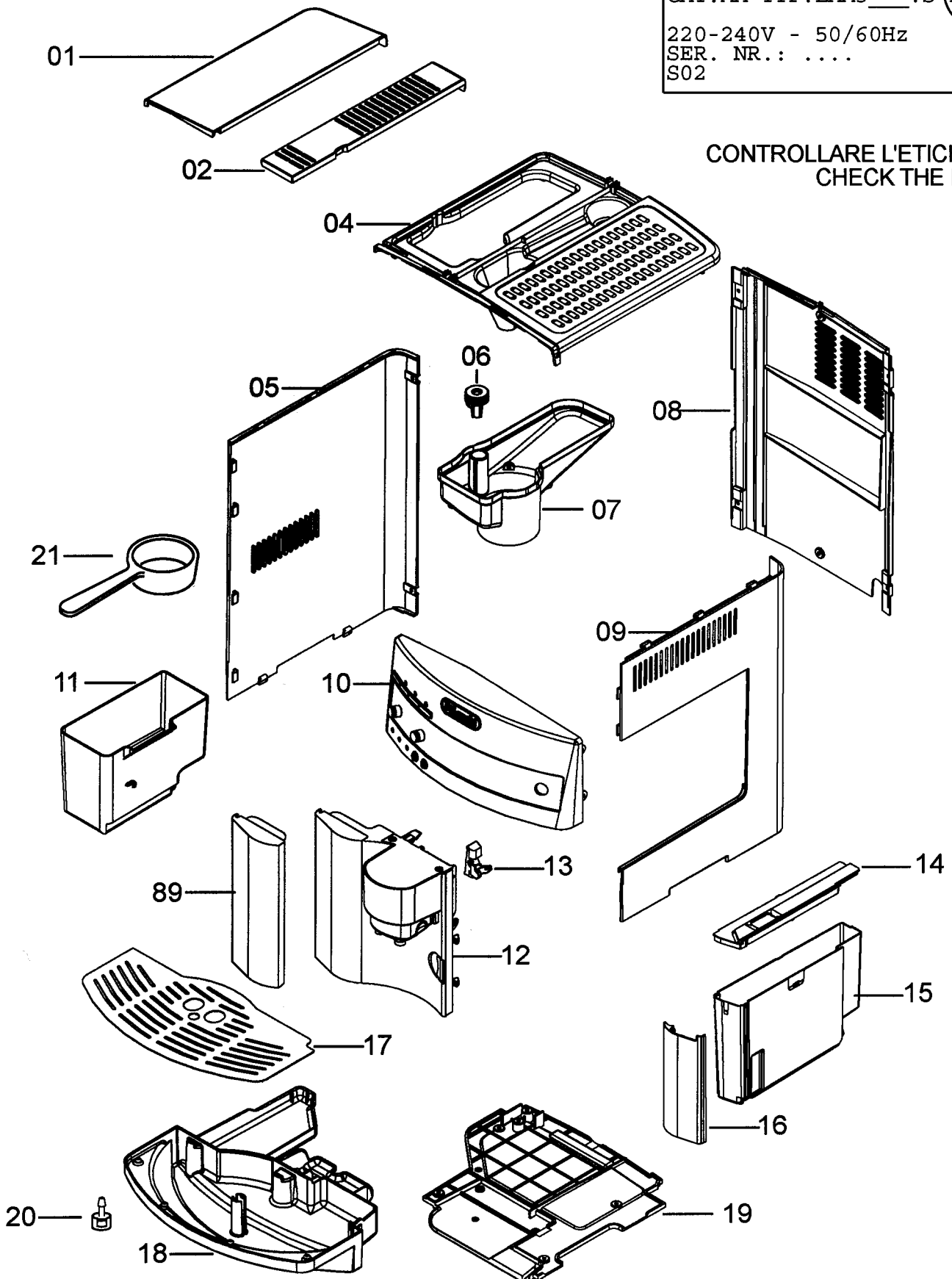

**ETICHETTA
COLLAUDO**
TEST LABEL

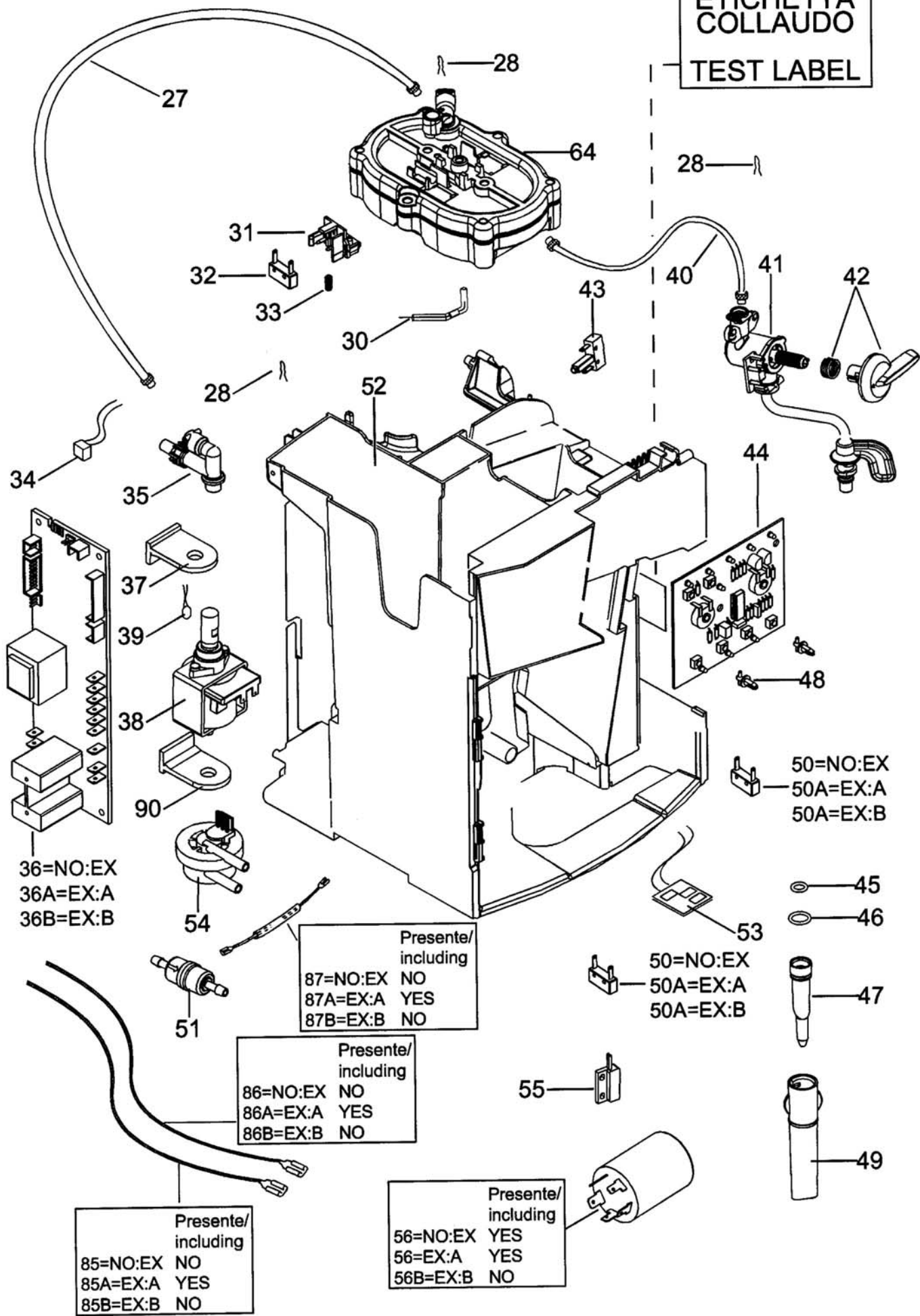

36=NO:EX
36A=EX:A
36B=EX:B

Presente/ including	
85=NO:EX	NO
85A=EX:A	YES
85B=EX:B	NO

Presente/ including	
86=NO:EX	NO
86A=EX:A	YES
86B=EX:B	NO

Presente/ including	
87=NO:EX	NO
87A=EX:A	YES
87B=EX:B	NO

Presente/ including	
56=NO:EX	YES
56=EX:A	YES
56B=EX:B	NO

50=NO:EX
50A=EX:A
50A=EX:B

50=NO:EX
50A=EX:A
50A=EX:B

45
46

47

49

ETICHETTA
COLLAUDO
TEST LABEL

CCCC **EE** SSSSS PPPP

**PER ORDINARE CONTROLLARE L'ETICHETTA
← TO PLACE AN ORDER CHECK THE LABEL**

**AA=62
AB=62B**

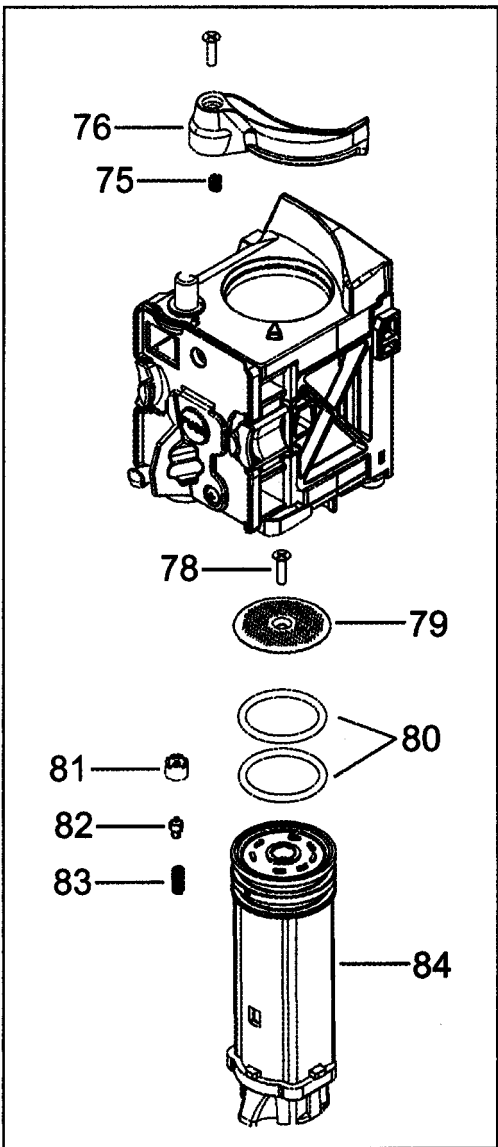
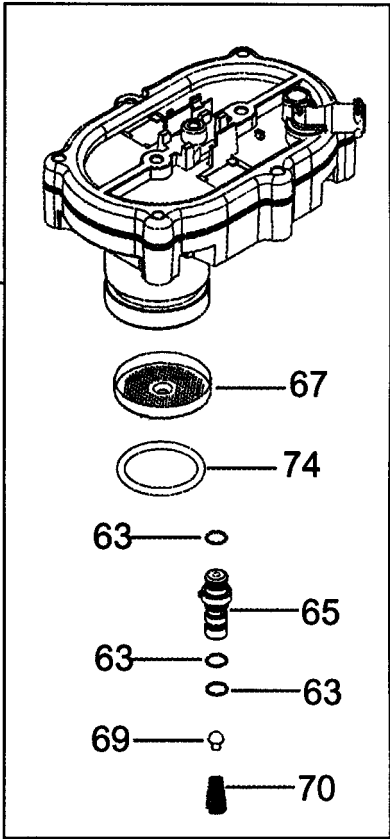
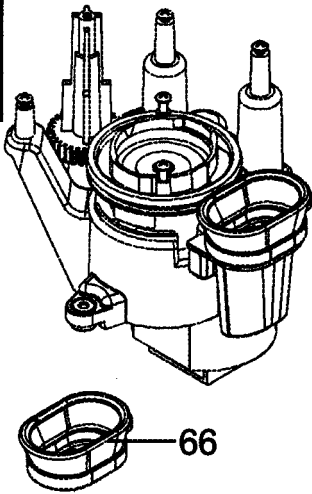

68=NO:EX
68=EXA
68B=EX:B

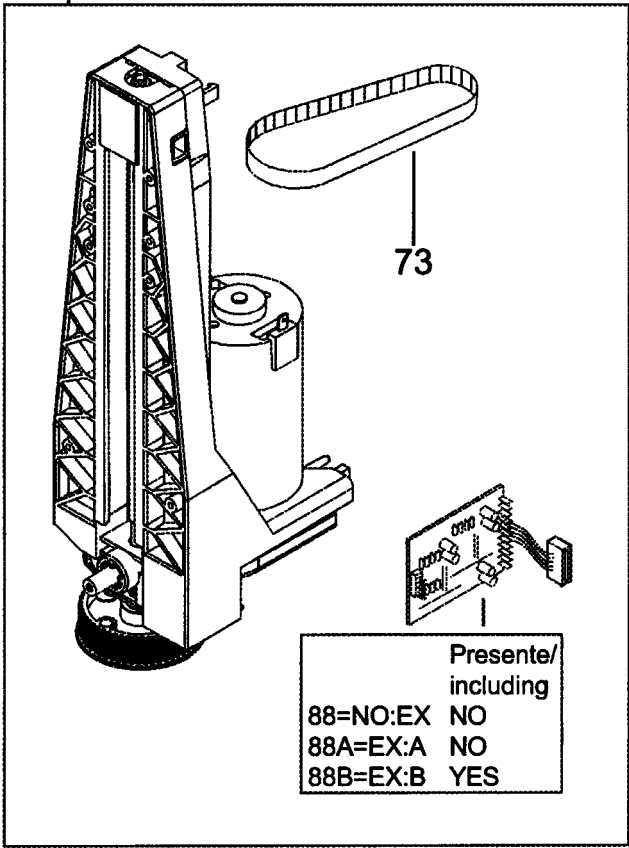

	Presente/ including
88=NO:EX	NO
88A=EX:A	NO
88B=EX:B	YES

Posizione	Codice	Descrizione
	7313217261	ASS. MOTORE (ECM)
	5032514800	CABLAGGIO FLUSSIMETRO L470
	5313210401	COPERCHIO
	5332224100	CINGHIA MOTORE MACININO
	5332164700	PATTINO TELAIO
	5313215891	GOMMINO ANTIMACCH GREY(EPDM70Z 70SH)MCSA
	6913210021	SUPPORTO EL.VALVOLA 2VIE(S.VAP)SGSS MCSA
	6913210031	SUPPORTO EL.VALVOLA 3VIE SGSS MCSA
	5332173800	BICCHIERE EROGATORE(ABS)NERO MCSA
	5332152000	MANIGLIA BICCHIERE CROMATA
	5332177900	COPERCHIO CAMERA ESPANSIONE(PP)EAM3IFD
	SER0354	GRASSO LUBRIFICANTE VERKOFOOD WR2 TUBO 5GR
	IT1000	TERMOMETRO DIGITALE PORTATILE, -50° +150°
01	5332143500	COPERCHIO
02	5332143400	COPERCHIETTO
04	7313224511	CHIUSURA
05	5332143900	FIANCO SX
06	5913210471	MANOPOLA
07	5532146600	SERBATOIO
08	5332168900	SCHIENALE
09	5332143800	FIANCO DX
10	7332172100	ASS. CRUSCOTTO
11	VI000	VEDI INFOTECNICA
12	7313220621	ASSIEME PORTA
13	5332142600	GANCIO
14	5332145600	COPERCHIETTO
15	7313228241	SERBATOIO ACQUA
16	5332151700	PROFILO
17	6032105000	POGGIATAZZE
18	5332144200	VASCHETTA
19	5332225800	FONDO
20	5332266300	GALLEGGIANTE
21	5332169200	MISURINO
27	7313285899	TUBO PTFE DI2-DE4 L=230 2BOCCOLE
28	6132101300	CLIP

30	5032513900	TCO
31	5332142200	SUPPORTO
32	5132104100	MICROINTERRUTTORE
33	6132104700	MOLLA
34	5217100200	SENSORE NTC
35	7313219431	VALVOLA
36B	5232109400	SCHEDA POTENZA
36A	5232105200	SCHEDA POTENZA
36	5232102900	SCHEDA POTENZA
37	5332225700	SUPPORTO
38	5113211281	POMPA
39	5232103200	PROTETTORE
40	5513213761	TUBO PTFE DI2-DE4 L=190 2BOCCOLE
41	7313216621	RUBINETTO
42	5513222451	MANOPOLA
43	5113210421	MICROINTERRUTTORE
44	5232110000	SCHEDA COMANDI 11 PIN
45	5313217761	O-RING
46	533135	O-RING
47	5332113800	TUBO INFERIORE
48	5332146600	PROLUNGA
49	5332229600	COPERTURA
50A	5132105400	MICROINTERRUTTORE
50	5113210421	MICROINTERRUTTORE
51	5513220521	FILTRO
52	VI000	VEDI INFOTECNICA
53	5213213971	SENSORE HALL
54	5213214671	FLUSSIMETRO
55	5232104600	SENSORE REED
56	5132104600	FILTRO RETE
56	5132105000	FUSIBILE
62B	5513227971	MACININO COMPLETO
62	IT0087	VEDI INFOTECNICA
63	5313217751	O-RING
64	5513227921	STG GENERATORE 230V
65	5332184900	PERNO
66	5332144900	GUARNIZIONE
67	5332139200	FILTRO

68B	5513227951	KIT TRASMISSIONE
68	5513227951	KIT TRASMISSIONE
69	5332148400	VALVOLA
70	6132106900	MOLLA
71	5332142300	BUSSOLA
72	5332142400	BUSSOLA
73	5313243071	CINGHIA
74	5332149100	O-RING
75	6132103500	MOLLA
76	5332139800	LEVA
77	7313251441	KIT INFUSORE
78	9812631250	VITE
79	6013213181	FILTRO (TAI-FENG)
80	5332149100	O-RING
81	5332139600	TAPPO
82	5332139500	VALVOLA
83	6132106700	MOLLA
84	5332140300	PISTONE
85A	5032515900	RESISTENZA CAVO VERDE
86A	ES000	*ESAURITO
87	5132105000	FUSIBILE
88B	5213212381	SCHEDA MOTORE (ECM)
89	5332151600	COPERTURA
90	534848	SUPPORTO
91	7332166600	SLITTA